



Premier Fluid Systems Inc.

Canadian Home of Travaini Pumps



APPLICATION SHEET

Application: Asphalt Plant Hot Oil Circulation Pumps

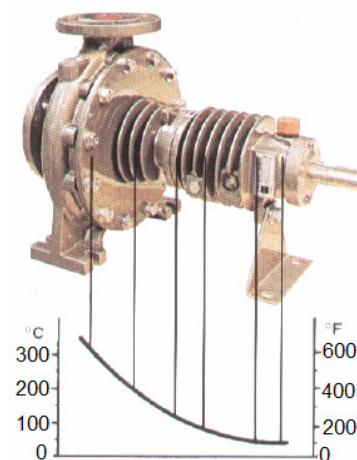

Keep your Asphalt Plant Running

Excessive heat to the seals and bearing lubrication oil will result in a premature failure for your hot oil circulation pump. The TCD series pumps are specifically designed to keep the heat away from these critical elements to keep your Asphalt Plant running. Designed to operate with fluid temperatures as high as 600°F (320°C) bearings and seals are kept well below critical temperatures.

No bearing and seal will last forever, so when they do eventually wear out, smart engineering made the pump quick and easy to service. These pumps can be retrofitted to any existing hot oil circulation system and are available with flow rates as high as 1800 USGPM (400 m³/h).

PREMIER FLUID SYSTEMS

www.pfspumps.com

4460 Harvester Road, Burlington ON L7L 4X2

Ph: 800-461-2611 Fx: 905-333-4722